

Stand for C3610DRJ (376510)

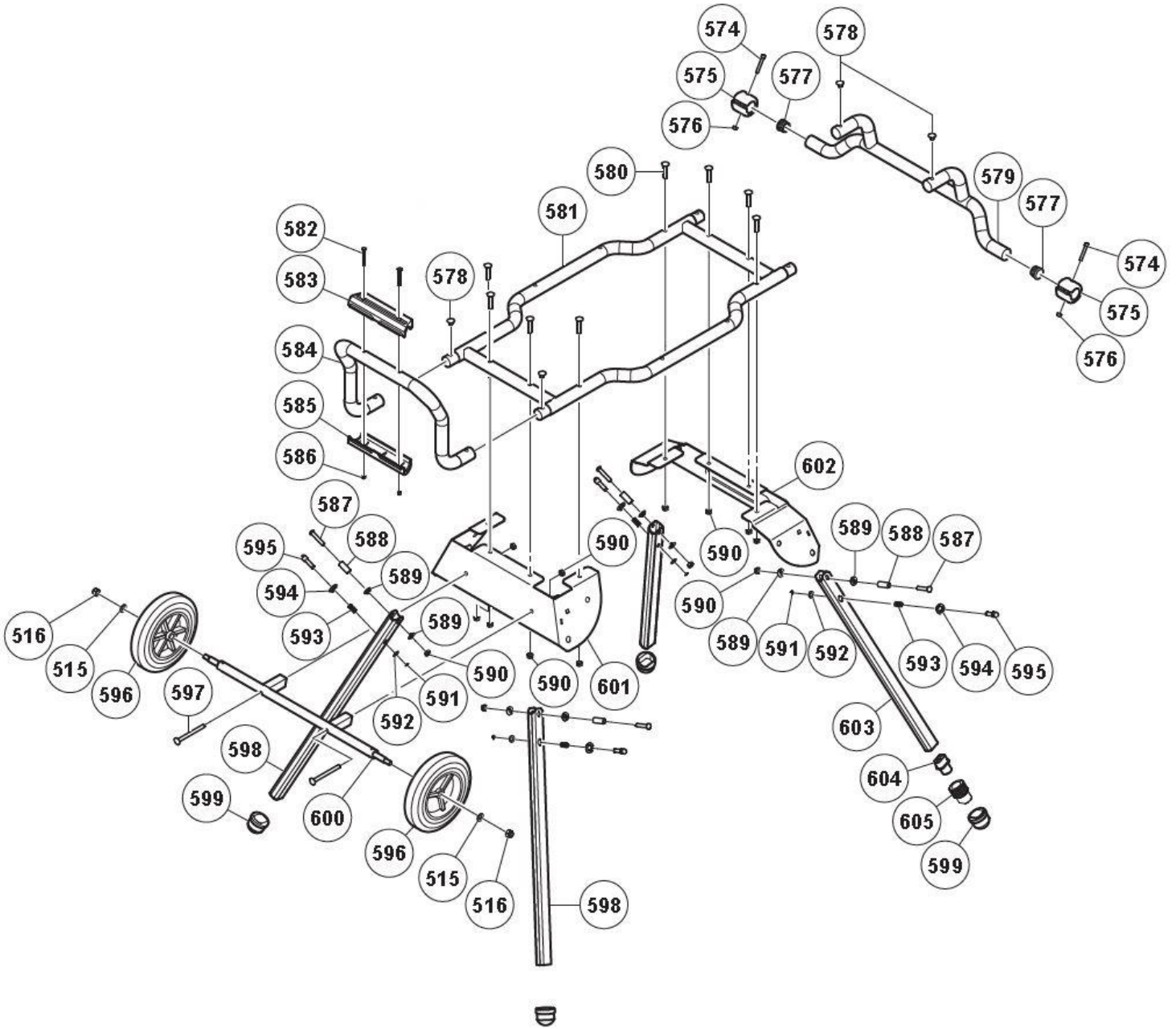

Position	Item Number	Description	Qty used
515	371515	FLAT WASHER	3
516	371514	HEX. NUT M10	4
574	371413	HEX. SOCKET CAP SCREW M6X40	2
575	371412	FOOTING	2
576	371411	LOCK NUT M6	3
577	371414	END CAP	2
578	371416	HEX. SOCKET BUTTON HEAD SCREW	4
579	371415	HANDLE ASS'Y	1
580	371417	HEX. SOCKET BUTTON HEAD SCREW M8X45	8
581	371410	HORIZONTAL SUPPORT TUBE ASS'Y M6X40	1
582	371422	CROSS PAN HEAD SCREW M5X45	2
583	371421	SUPPORT PAD (A)	1
584	371420	SUPPORT TUBE ASS'Y	1
585	371419	SUPPORT PAD (B)	1
586	371418	LOCK NUT M5	2
587	371398	LEG BOLT	4
588	371639	LEG STOP COLLAR	4
589	371397	FRICITION PAD 8	8
590	371400	LOCK NUT M8	14
591	371392	SPLIT WASHER	4
592	371393	FLAT WASHER 8	4
593	371394	SPRING	4
594	371395	FRICITION PAD	4
595	371396	STOP PIN	4
596	371403	WHEEL	2
597	371402	HEX. SOCKET PLAIN ROUND HEAD SCREW M8X90	2
598	371391	STAND LEG (A)	3
599	371390	STAND FOOT	4
600	371401	WHEEL SHAFT ASS'Y	1
601	371399	SUPPORT PLATE ASS'Y (A)	1
602	371409	SUPPORT PLATE ASS'Y (B)	1
603	371408	ADJUSTABLE LEG	1
604	371407	ADJUSTABLE FOOT (A)	1
605	371406	ADJUSTABLE FOOT (B)	1