

ENGINE TOOL PARTS LIST

ENGINE POLE SAW Model CS 27EPAP

2012-9-13
(E1)

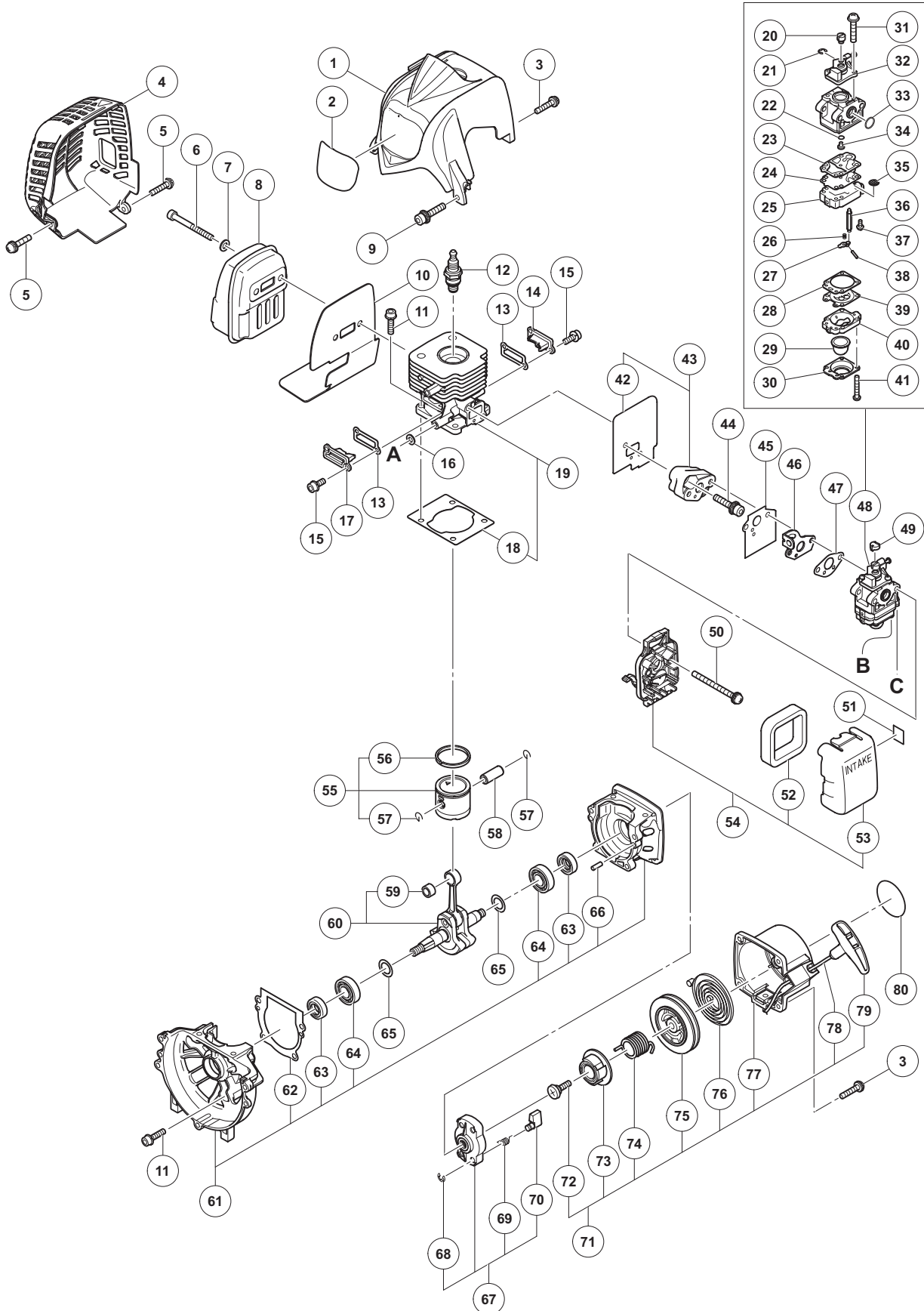

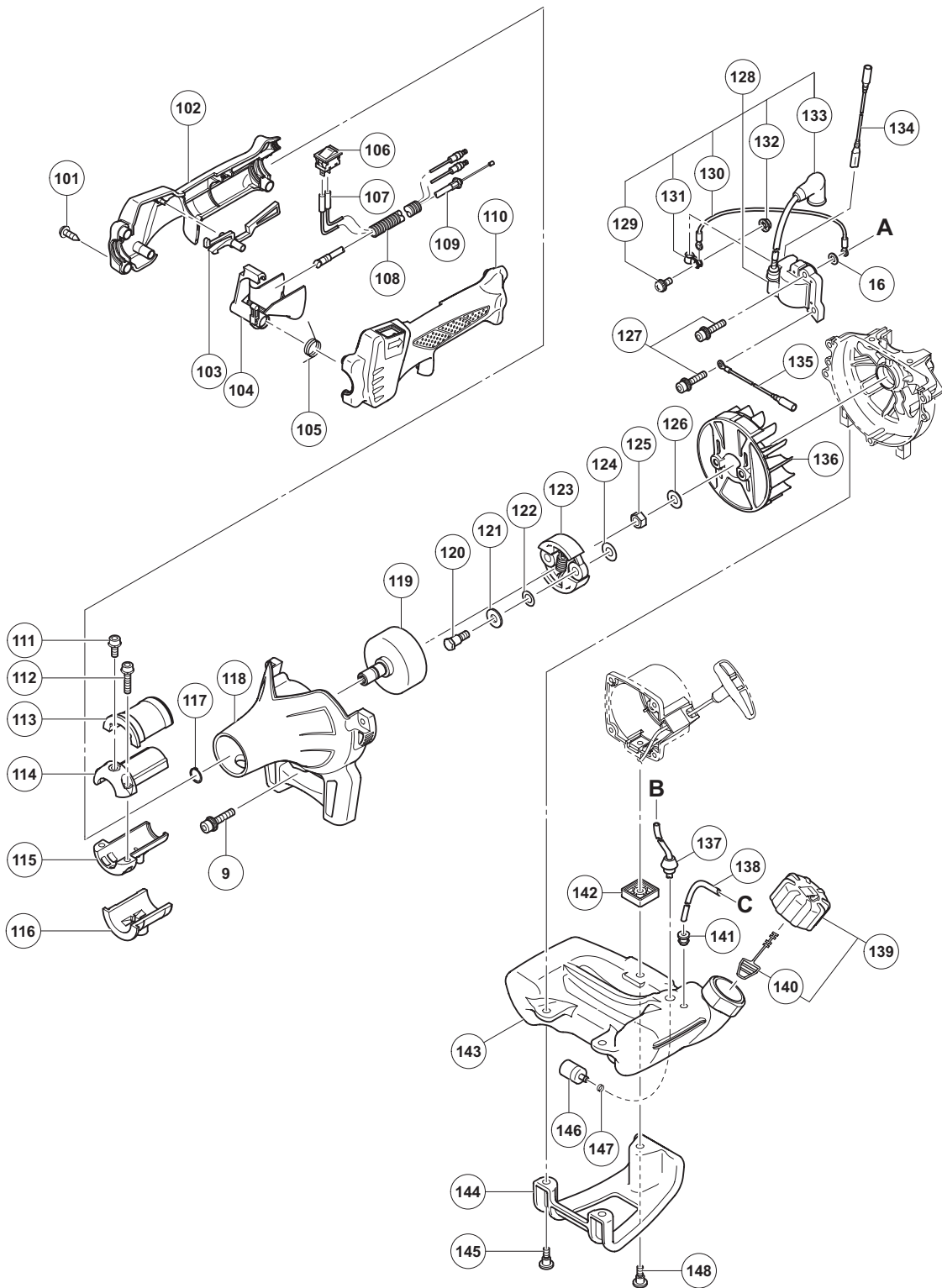

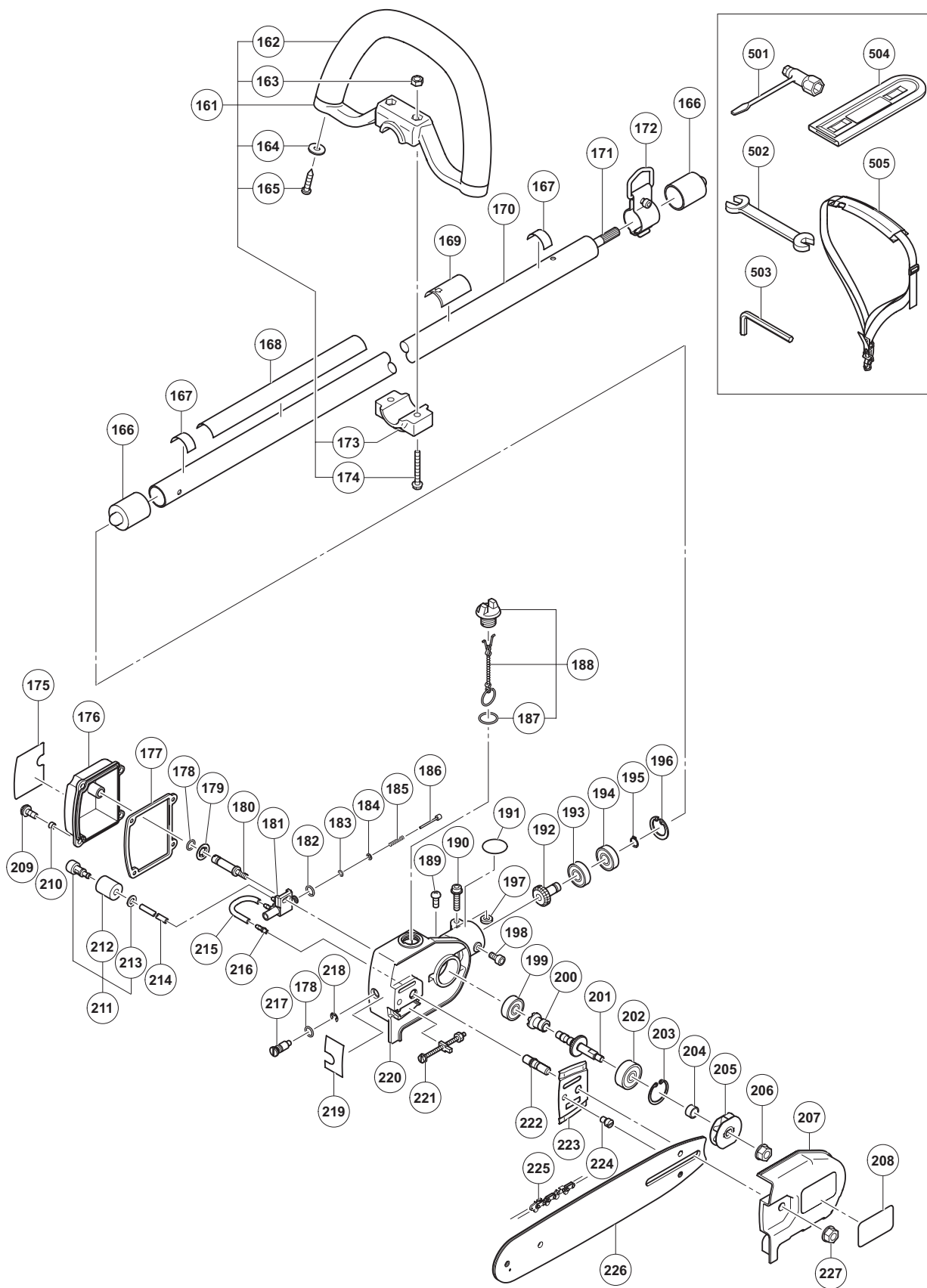

PARTS

CS 27EPAP

ITEM NO.	CODE NO.	DESCRIPTION	NO. USED	REMARKS
1	669-8481	CYLINDER COVER	1	
2		HITACHI LABEL	1	
3	669-5376	SCREW 4 X 22/PS	4	
4	669-8494	MUFFLER COVER	1	
5	669-5386	SCREW 5 X 16/PS	2	
6	669-5067	HEX. HOLE BOLT 6 X 65	2	
7	668-4639	BOLT WASHER 6	2	
8	669-8476	MUFFLER (B)	1	
9	669-8950	SEAL LOCK HEX. SOCKET HD. BOLT M5 X 30	3	
10	669-8491	HEAT PROTECTION PANEL	1	
11	669-5491	HEX. HOLE BOLT 5 X 20S	8	
12	668-4584	SPARK PLUG BMR7A	1	
13	669-7684	COVER PACKING	2	
14	669-8484	SCAVENGING COVER (A)	1	
15	669-5507	HEX. HOLE BOLT 4 X 12WS	4	
16	668-4600	WASHER T1.6	2	
17	669-8485	SCAVENGING COVER (B)	1	
18	669-7681	CYLINDER GASKET	1	
19	669-7679	CYLINDER SET PN	1	INCLUD. 18
20	668-4697	SWIVEL	1	
21	668-4696	STOP RING	1	
22	668-4695	O-RING	1	
23	668-4692	PUMP GASKET	1	
24	668-4693	PUMP DIAPHRAGM	1	
25		PUMP BODY	1	
26	669-6323	METERING LEVER SPRING	1	
27	668-5217	CONTROL LEVER	1	
28	668-4691	DIAPHRAGM GASKET	1	
29	668-4689	PRIMING BODY	1	
30	668-4688	DIAPHRAGM COVER	1	
31	668-4698	THROTTLE SET SCREW	2	
32	668-4883	THROTTLE VALVE	1	
33	669-5670	O-RING P-15	1	
34		MAIN JET #32	1	
35	668-4700	INLET SCREEN	1	
36	668-5215	NEEDLE VALVE	1	
37	669-1305	HINGE PIN SET SCREW	1	
38	668-5219	HINGE PIN	1	
39	668-4690	METERING DIAPHRAGM	1	
40	668-4687	PRIMING PUMP COMP.	1	
41	668-4699	SET SCREW	4	
42	669-7691	INTAKE PACKING	1	
43	669-8954	CARBURETOR INSULATOR SET PN	1	INCLUD. 42
44	669-8844	SEAL LOCK HEX. SOCKET BOLT (W/WASHERS) M5	2	
45	668-4616	CARBURETOR PACKING	1	
46	668-4629	THROTTLE WIRE FIXING PLATE	1	
47	668-4615	CARBURETOR GASKET	1	
48	669-8960	CARBURETOR ASS'Y	1	INCLUD. 20-41
49	668-4628	SWIVEL CAP	1	
50	669-5431	PLUS SCREW 5 X 60WS	2	

PARTS

CS 27EPAP

ITEM NO.	CODE NO.	DESCRIPTION	NO. USED	REMARKS
* 51		MARK PLATE (T)	1	
* 51		MARK PLATE (EU)	1	
52	669-0347	CLEANER ELEMENT	1	
53	669-0139	AIR CLEANER CAP	1	
54	669-8961	AIR FILTER ASS'Y	1	INCLUD. 52, 53
55	669-7683	PISTON SET PN	1	INCLUD. 56, 57
56	668-6121	PISTON RING	1	
57	668-4590	CIR CLIP	2	
58	668-4591	PISTON PIN	1	
59	669-5590	NEEDLE BEARING HK0810B	1	
60	669-8969	CRANK SHAFT ASS'Y	1	INCLUD. 59
61	669-7687	CRANK CASE ASS'Y	1	INCLUD. 62-64, 66
62	669-7688	CRANK CASE PACKING	1	
63	668-4607	OIL SEAL TB 12227	2	
64	668-4608	BALL BEARING 6001 C3	2	
65	669-7685	CRANK SHAFT WASHER	2	
66	669-5521	KNOCK PIN 4 X 12	2	
67	668-4681	STARTER PULLEY ASS'Y	1	INCLUD. 68-70
68	668-4683	STOP RING E-5	2	
69	668-4684	STARTER PAWL SPRING	2	
70	668-4685	STARTER PAWL	2	
71	668-4672	RECOIL STARTER BODY ASS'Y	1	INCLUD. 72-79
72	668-4679	SET SCREW	1	
73	668-4678	CAM PLATE	1	
74	668-4677	DUMPER SPRING	1	
75	668-4676	STARTER ROPE REEL	1	
76	669-7591	RECOIL SPRING	1	
77	668-4673	RECOIL STARTER BODY COMP.	1	
78	669-7590	STARTER ROPE 3.5 X 860	1	
79	668-4680	STARTER HANDLE	1	
80		NAME PLATE	1	
101	669-7190	TAPPING SCREW D4	4	
102	669-6487	HANDLE (B)	1	
103	669-6490	LOCK LEVER	1	
104	669-6488	LEVER	1	
105	669-8819	SPRING (A)	1	
106	668-5239	STOP SWITCH	1	
107	669-8820	STOP SWITCH CORD	2	
108	669-8822	PROTECTION TUBE	1	
109	669-8821	THROTTLE WIRE	1	
110	669-6486	HANDLE (A)	1	
111	668-4667	HEX. HOLE BOLT M5 X 12/S	1	
112	668-4709	HEX. HOLE BOLT M5 X 25/S	2	
113	668-4666	ANTI-VIBE RUBBER (A)	1	
114	669-8643	PIPE HOLDER (A)	1	
115	669-8644	PIPE HOLDER (B)	1	
116	668-4665	ANTI-VIBE RUBBER (B)	1	
117	668-4664	STOP RING C-12 OUTER	1	
118	669-8486	FAN CASE	1	
119	668-4663	CLUTCH DRUM COMP.	1	

PARTS

CS 27EPAP

ITEM NO.	CODE NO.	DESCRIPTION	NO. USED	REMARKS
120	668-9627	STEP BOLT	2	
121	668-4648	BENT WASHER 8	2	
122	668-9528	CLUTCH PLATE (A)	2	
123	669-7655	CLUTCH SET	1	
124	669-7619	CLUTCH WASHER B	2	
125	668-4612	HEX. NUT M8	1	
126	668-4611	BOLT WASHER M8	1	
127	669-5508	HEX. HOLE BOLT 4 X 18WS	2	
128		IGNITION COIL ASS'Y	1	INCLUD. 129-133
129		SCREW	1	
130		EARTH CORD	1	
131		CLIP	1	
132		FLANGE NUT M4	1	
133		CORD	1	
134	669-8964	CORD	1	
135	669-7690	CORD	1	
136	669-8396	MAGNETO ROTOR COMP.	1	
137	668-4618	SHIELD TUBE 3 X 5 X 180	1	
138	668-4880	FUEL PIPE 3 X 5 X 85	1	
139	668-4622	TANK CAP ASS'Y	1	INCLUD. 140
140	668-4625	TANK CAP CHAIN	1	
141	668-4627	RETURN GROMMET	1	
142	669-8496	SPACER	1	
143	669-8475	TANK	1	
144	669-4787	STAND	1	
145	669-6557	FLANGE BOLT	2	
146	668-4620	PUMP FILTER BODY COMP.	1	
147	668-4619	CLIP, 6.3 DIA.	1	
148	669-8991	BOLT (W/FLANGE) L27.8	1	
161	669-6088	LOOP HANDLE ASS'Y ANTI-VIB.	1	INCLUD. 162-165, 173, 174
162	669-1098	HANDLE GRIP	1	
163	668-4835	HEX. NUT 6	2	
164	668-9681	BRAKE SHAFT WASHER	1	
165	669-5255	TAPPING SCREW 5 X 20	1	
166	669-8515	CAP (A)	2	
167	668-4851	LEVEL MARK	2	
168		CAUTION PLATE HITACHI	1	
169	668-4852	LEVEL MARK	1	
170	669-8823	MAIN PIPE COMP.	1	
171	668-9443	DRIVE SHAFT 1829L	1	
172	668-9277	HANGER D24	1	
173	669-1134	HANDLE BRACKET A	1	
174	668-4838	BOLT 6 X 43/P (BLACK)	2	
175	669-4578	OIL ADJUSTMENT MARK	1	
176	668-6138	OIL TANK COVER	1	
177	669-0084	OIL TANK GASKET	1	
178	669-5661	O-RING P-5	2	
179	669-5239	8 PUSH NUT	1	
180	668-9757	STEP BOLT A	1	
181	668-6487	OIL PUMP COMP.	1	

PARTS

CS 27EPAP

ITEM NO.	CODE NO.	DESCRIPTION	NO. USED	REMARKS
182	669-8965	O-RING	1	
183	669-5656	O-RING 1.4	1	
184	669-5187	WASHER 2	1	
185	669-0381	OIL PUMP SPRING	1	
186	668-6608	OIL PUMP PISTON COMP.	1	
187	669-8966	O-RING P-15	1	
188	669-2050	OIL TANK CAP ASS'Y	1	INCLUD. 187
189	669-5458	SCREW 6 X 8	1	
190	669-5492	HEX. HOLE BOLT 5 X 22/S	1	
191	669-4831	MANUAL LABEL	1	
192	669-8967	PINION	1	
193	668-4734	BALL BEARING 609	1	
194	668-4735	BALL BEARING 609Z ST	1	
195	669-5281	STOP RING C-9, OUTER	1	
196	668-4732	STOP RING C-24, INNER	1	
197	669-3248	STARTER PAWL WASHER	1	
198	669-5042	HEX. HOLE BOLT 5 X 10	1	
199	669-5568	BALL BEARING 627 C3	1	
200	669-0428	CAM	1	
201	669-8968	GEAR	1	
202	669-7603	BALL BEARING 638Z	1	
203	668-4741	STOP RING C-28, INNER	1	
204	668-5962	COLLAR	1	
205	668-9117	SPROCKET COMP., 3/8	1	
206	669-5170	FLANGE NUT 6	1	
207	668-6038	SIDE COVER COMP.	1	
208	669-4763	SYMBOL MARK HITACHI	1	
209	669-5403	SMALL SCREW 4 X 12WS	4	
210		COLLAR 3	4	
211	669-0913	FILTER ASS'Y	1	INCLUD. 212, 213
212	669-0917	OIL FILTER	1	
213	668-4661	WASHER 5	1	
214	669-2414	FUEL PIPE 3 X 5 X 60	1	
215	669-2415	FUEL PIPE 3 X 5 X 75	1	
216	668-6637	BANJO, OIL PUMP	1	
217	669-1066	OIL PUMP ADJUSTER	1	
218	669-5311	STOP RING E-6	1	
219	669-4576	OIL MARK	1	
220	668-5793	CASE	1	
221	668-7063	CHAIN TENSIONER	1	
222	668-6803	CHAIN BAR TIGHTENING BOLT	1	
223	669-7596	GUIDE PLATE	1	
224	668-7130	CHAIN BAR KNOCK PIN	1	
225	668-7176	SAW CHAIN, 10 INCH, 3/8	1	
226	668-6882	CHAIN BAR 10	1	
227	668-7105	CHAIN BAR CLAMP NUT	1	

